

Industrial Ethernet Optical Fiber Link Adapter

FIB-IE-M

User Manual



FOURSTAR Electronic Technology Co., Ltd.

All rights reserved

Contents

Preface.....	3
Copyright	3
Version information	3
Product list	4
1. Overview	4
2. Product Features and Main Technical Parameters	5
3. Product Appearance and Parts Description	6
4. User Guide	7
4.1 Typical application 1	8
4.2 Typical application 2	8
5. Link Fault Pass	9
6. Commonly Used Network Topological Structure	10
6.1 Bus network topological structure	10
6.2 Star network topological structure	11
7. Order Information	12

Preface

Thank you for using industrial Ethernet optical fiber link adapter manufactured by FOURSTAR Electronic Technology Co., Ltd.

Be sure to read this manual carefully before use. The product specifications and information referred to in this manual are for reference only, subject to updates without prior notice. It's used as a guide only. All statements and information in the manual do not constitute any form of warranty. The Company reserves the right to modify the content of this manual and product features according to the needs of the technological development without prior announcement and shall not assume the property damage or personal injury caused by user's improper operation.

FOURSTAR[®]
四星电子 is a registered trademark of FOURSTAR Electronic Technology Co., Ltd. All other trademarks or registered trademarks mentioned in this document are owned by their respective trademark owners.

Copyright

Without written permission from FOURSTAR Electronic Technology Co., Ltd., no individual or institution is allowed to imitate, copy or translate the document in whole or in part. It shall not be spread in any form (electronic, mechanic, photocopy, recording or other possible means) or used for any commercial purposes.

Copyright© 2013 FOURSTAR Electronic Technology Co., Ltd. All rights reserved.

Version information

Document name: User Manual of Industrial Ethernet Optical Fiber Link Adapter FIB-IE-M

Revision history

Version	Revision date	Reason for revision
V2.0	2013-03-08	Creation of document
	2013-04-18	Modification of some pictures

Product List

1. One set of industrial Ethernet optical fiber link adapter FIB-IE-M.
2. One copy of user manual in print or CD-ROM. (this product does not require any driver software).

1. Overview

With the rapid development of industrial Ethernet technology and applications of large number of its products, the Ethernet has become one of the most popular industrial control communication networks with its advantages in low price, high reliability, high-speed communications, rich hardware and software products, wide application and mature support technology, etc. In recent years, with the development of network technology, Ethernet enters the automation control field to form a new industrial Ethernet control network technology, which is mainly due to industrial automation systems that develop in the direction of distributed and intelligent control, The open communication protocol and the simplicity in use have been widely recognized by the industrial control industry and many industrial control equipments have been equipped with industrial Ethernet interfaces.

The Ethernet signal transmission distance can only reach 100m, which becomes a bottleneck restricting industrial Ethernet applications. We know that in the distributed control system, the distances between I/O equipments may reach a few kilometers to tens of kilometers. To transfer the Ethernet signal over such long distance in real time, the use of optical fiber is currently the best choice. In addition to achieving high-speed long-distance signal transmission, it also can eliminate grounding circuit interference, resist electromagnetic interference and lightning and many other advantages.

FIB-IE-M can be widely used in PLC, HMI, VVVF, DCS and other industrial equipments based on Industrial Ethernet.

2. Product Features and Main Technical Parameters

- Power supply voltage: 9-40VDC wide voltage range not affected by voltage fluctuation with the power consumption at approximately 2 watts.
- Power port, Ethernet port and all fiber ports are insulated with the isolation voltage of 1500Vrms.
- Comply with IEEE802.3u, 10/100Base-TX and 100Base-FX Industrial Ethernet standards.
- Link Fault Pass-through.
- Transmission rate: Ethernet port 10/100M self-adaptive, optical port 100M.
- The Ethernet port with the MDI/MDI-X auto-crossover function can automatically adapt to the straight-through cables and crossover cables.
- Fiber optical connectors: standard ST connector, optional SC or FC connector.
- Wavelength: 1310nm.
- Applicable fiber: multimode 62.5/125um and 50/125um.
- Maximum transmission distance: Cat.5 cable, 100m, multimode optical fiber 5km.
- Equipped with power supply, optical fiber and cable port status indicator.
- Operating temperature: -20~+75°C.
- Dimensions: 85mm*49mm*100mm (L*W*H)
- Weight: 170g.
- Installation: DIN35mm standard rail mounting or bolted installation.

3. Product Appearance and Component Description



Figure 3-1 FIB-IE-M external structure

● Power plug:

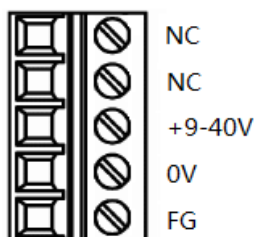

Plug name	Description
NC	No connection
NC	No connection
+9-40V	Connect to the anode of any direct current of 9-40V
0V	Connect to the cathode of any direct current of 9-40V
FG	Shield grounding (casing grounding)

● LED indicator

LED indicator	Normally on	Blink	Off
PWR	Power on	Product fault	Power off or product failure
LFP	Link fault pass function is enabled	Product fault	Link fault pass function is disabled
TP-SPD	The Ethernet port is connected with 100M device	Product fault	The Ethernet port is connected with 10M device
TP-FDX/Col	The Ethernet port operates in full-duplex mode	The Ethernet port data conflicts	The Ethernet port operates in half-duplex mode
TP-Link/Act	The Ethernet port is correctly connected	The Ethernet port is transferring data	The Ethernet port is not connected
FX-Link/Act	Optical fiber is correctly connected	The optical port is transferring data	The optical fiber is not connected

● Link Fault Pass Switch:

Switch position	Function	Remarks
LFP_ON	Enable link fault pass	
LFP_OFF	Disable link fault pass	Factory default

Note: after turning the switch, the new settings will not take effect until power on again.

4. User Guide

Before installing the Ethernet optical fiber link adapter, please confirm that the connected network cable (Cat. 5 twisted pair) can not exceed 100m in length and the maximum length of the optical fiber cannot exceed that specified by the user manual, which is 5km in multimode and 20km in single mode.

The fiber ports of two Ethernet optical fiber link adapters will always follow the principal of “sending port connects to receiving port and receiving port connects to sending port”, which is Tx-Rx, Rx-Tx.

4.1 Typical application 1:

Figure 4-1 is the connection diagram of typical application 1 of Ethernet optical fiber link adapter. The network equipment A and network equipment B in the figure are both equipped with 10/100Base-TX Ethernet interface and can realize long-distance optical fiber connection between network equipment A and network equipment B with optical fiber through two optical fiber link adapters.

The network equipments A and B can be the Ethernet servers, workstations, routers, switches, hubs, PLC with Ethernet port, touch screens, inverters and other industrial control equipments, as well as other equipments with Ethernet port.

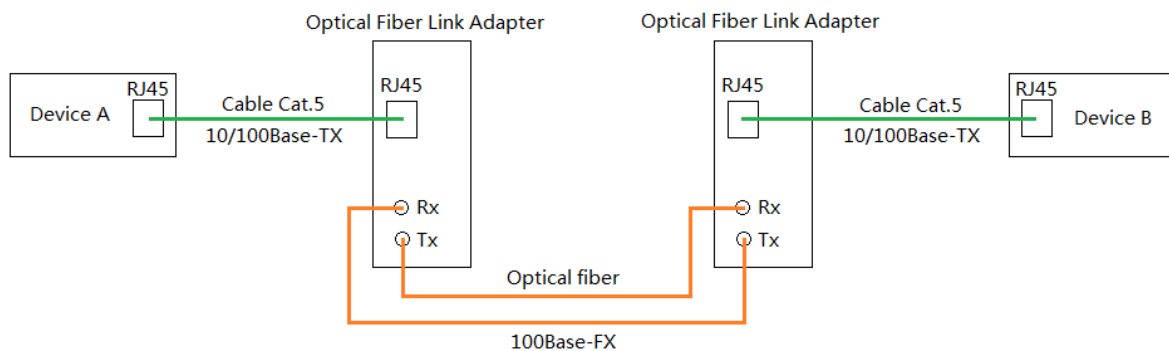

Figure 4-1 Typical application 1

4.2 Typical application 2:

Figure 4-2 is the connection diagram of typical application 2 of Ethernet optical fiber link adapter. The network equipment A with 10/100Base-TX Ethernet port is connected to the RJ45 Ethernet port of the optical fiber link adapter through twisted-pair cable and another network equipment C with 10/100Base-FX fiber interface is connected to the fiber interface of optical fiber link adapter through optical fiber, then the interconnection of the network equipments can be realized.

The network equipments A and C can be Ethernet servers, workstations, routers, switches,

hubs, PLC with Ethernet port or optical port, touch screens, inverters and other industrial control equipments, as well as other equipments with Ethernet port or optical port.

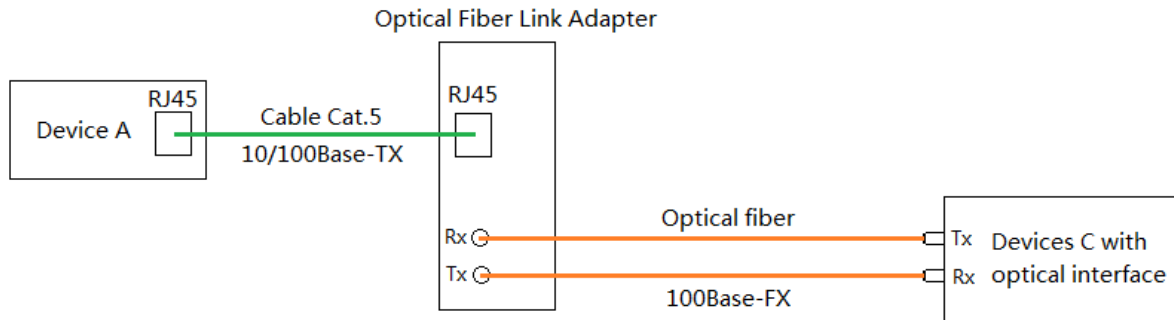

Figure 4-2 typical application 2

5. Link Fault Pass

When LFP_ON/OFF switch is turned to LFP_ON position, the link fault pass function is enabled after the optical fiber adapter is powered on. This function will force other ports of this link to stop transmission when automatically detecting any port on the link that is disconnected.

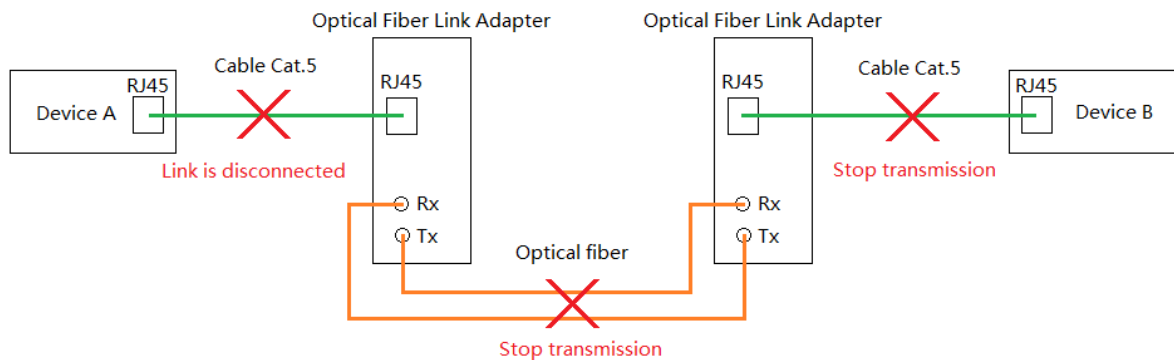

Figure 5-1 Link Fault Pass

As shown in Figure 5-1, when the cable of network equipment A is disconnected, the two optical fiber link adapters and the network equipment B will stop transferring data. Then the indicator status of each device is as follows:

Network equipment A	Link/Act indicator off
Network equipment B	Link/Act indicator off
Optical fiber link adapter	LFP light on
	TP-Link/Act indicator off
	FX-Link/Act indicator off

6. Commonly Used Network Topologic Structure

6.1 Bus network topological structure:

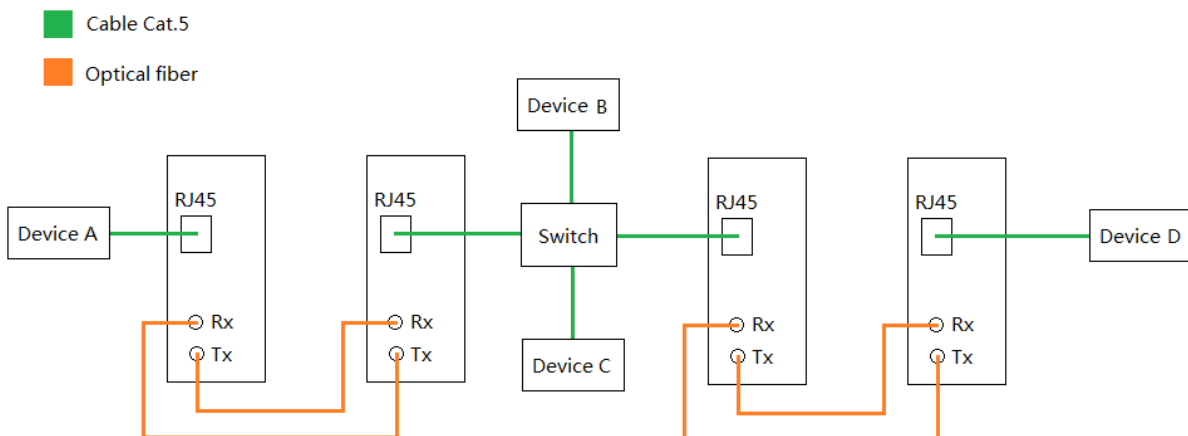

Figure 6-1 bus network topological structure

6.2 Star network topological structure:

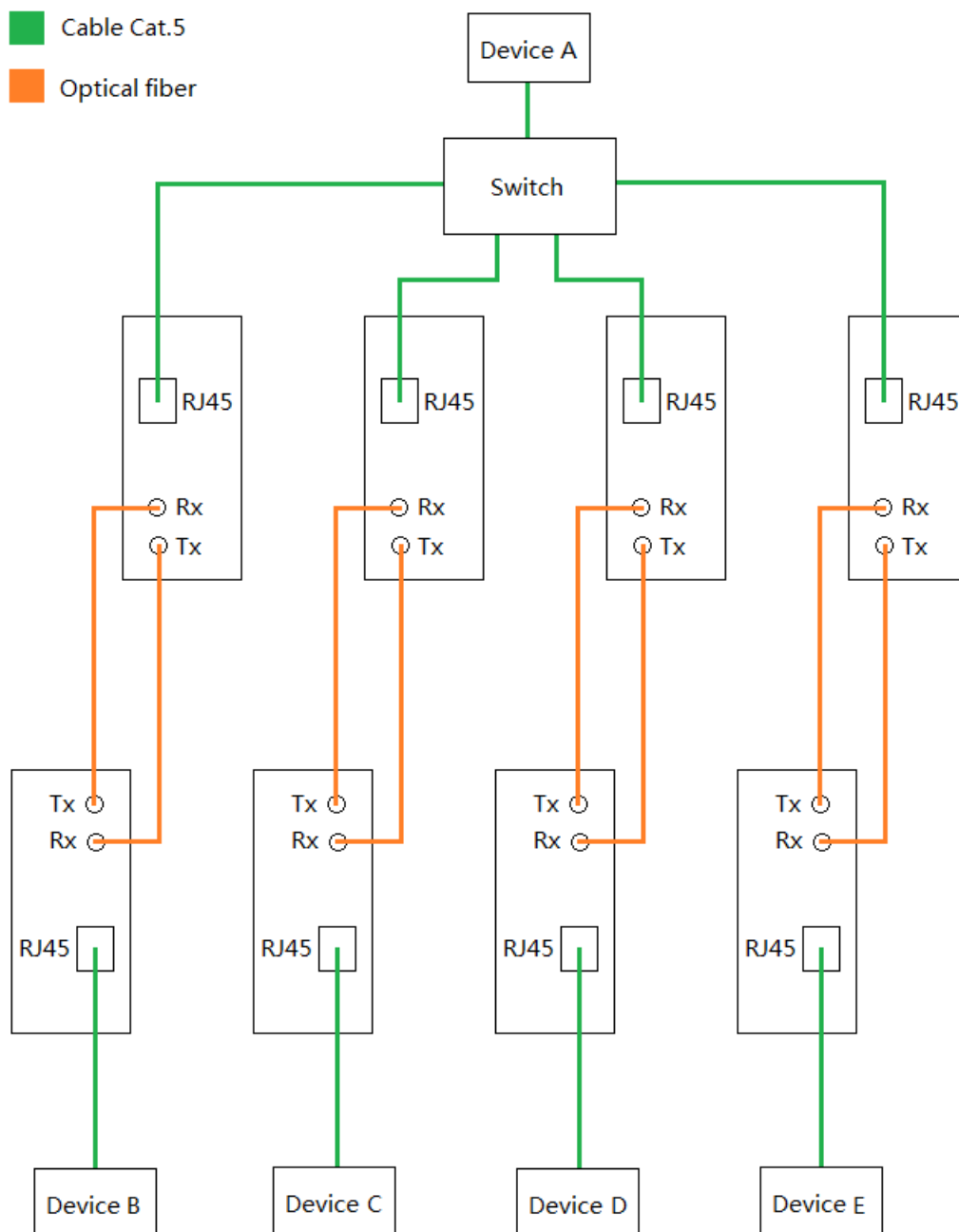

Figure 6-2 Star network topological structure

7. Order information

Product name: Industrial Ethernet Optical Fiber Link Adapter

Model: FIB-IE-M

Note: this document is to provide guidance for the user to use FIB-IE-M Industrial Optical Fiber Link Adapter. The product functions shall be subject to the functions on the actual device due to the rapid development of new technology. FOURSTAR Electronic Technology Co., Ltd. reserves the right to modify the document without any prior notice.

FOURSTAR Electronic Technology Co., Ltd.

Address: 2/F, Building H, No.88, Section 2, Lushan Road South , Deyang City, Sichuan Province, China.

Tel: +86-838-2515543 2515549

Fax: +86-838-2515546

Website: <http://www.fourstar-dy.com>